

# PMD effect on measurements of distributed chromatic dispersion in DSF fibers

H. Chen\*, M. Leblanc and G. W. Schinn

*EXFO Electro-Optical Engineering Inc., 465 Godin Ave., Vanier, Quebec, G1M 3G7, Canada*

\*Tel : (418) 683-0211, Fax: (418) 683-8073; E-mail: hongxin.chen@exfo.com

C. Vinegoni, M. Wegmuller and N. Gisin

*Group of Applied Physics, University of Geneva, CH-1211 Geneve 4, Switzerland*

## ABSTRACT

We report PMD effect on the distributed chromatic dispersion map measurement based on phase mismatched four-wave mixing. Experimental results of the distributed chromatic dispersion map for a low PMD dispersion-shifted fiber are described with spatial resolution of 250 m and dispersion accuracy less than  $\pm 0.02$  ps/nm.km. For high PMD dispersion-shifted fibers chromatic dispersion map may be difficult to be resolved if the fiber is with long polarization coupling length, but will still be possible measurable for a low polarization coupling length fiber. Finally to determine distributed nonlinear coefficient with this method is also discussed.

**Keywords:** distributed chromatic dispersion, four-wave mixing, nonlinear coefficient, polarization mode dispersion, optical-time-domain-reflectometer.

## 1. INTRODUCTION

Recently there has been a surge of interest in the measurements of distributed chromatic dispersion (CD) along optical fiber for the dispersion management in the design of ultrahigh capacity optic fiber transmission systems<sup>1-7</sup>. Nonlinear effects, such as four-wave mixing (FWM)<sup>8-16</sup> and cross-phase modulation (XPM)<sup>17, 18</sup>, may seriously affect an optical transmission system even with small chromatic dispersion (CD), *e.g.* in dispersion-shifted fibers (DSF). There are several methods of either modulation instability, or phase matching of four-wave mixing<sup>1-3</sup>, or bidirectional optical-time-domain-reflectometer (OTDR) technique<sup>5, 6</sup> for measuring the spatial resolved chromatic dispersion map as a function of fiber length. A convenient way of measuring the chromatic dispersion map is an OTDR-like technique that was proposed by Mollenauer *et al* in 1996 based on the phase mismatching of four-wave mixing<sup>1</sup>.

In practice four-wave mixing leads to important impairments for optical transmission systems. However, FWM can also be used to measure fiber parameters such as chromatic dispersion and nonlinear coefficient<sup>12</sup> because the FWM efficiency depends on both the fiber chromatic dispersion and the nonlinear coefficient  $n_2/A_{\text{eff}}$ .

In this paper we describe PMD effect on the distributed chromatic dispersion measurements based on the phase mismatched four-wave mixing. Experimental results of the distributed chromatic dispersion measurement for a low PMD dispersion-shifted fiber are presented with spatial resolution of 250 m and dispersion accuracy less than  $\pm 0.02$  ps/(nm.km). For high PMD dispersion-shifted fibers chromatic dispersion map may be difficult to be resolved if fiber is with a long polarization coupling length, but will still be possible measurable for a low polarization coupling length fiber. Finally a measurement of distributed nonlinear coefficient  $n_2/A_{\text{eff}}$  was also studied.

## 2. THEORY

The method of OTDR-like technique to measure a distributed chromatic dispersion map is to detect the fringe period of the Rayleigh back-scattered FWM signal, either Stokes or anti-Stokes, generated from the

fiber under test (FUT) by injecting two powerful lights with frequencies  $\omega_1$  and  $\omega_2$  ( $\omega_1 < \omega_2$ ). Concentrating on the FWM generated from Stokes frequency  $\omega_S = 2\omega_1 - \omega_2$  for simplicity, one can show that the phase mismatch  $\Delta k$  between the pump ( $\omega_1$ ) and the generated Stokes signal ( $\omega_S$ ) becomes<sup>1</sup>

$$\Delta k = \Delta k_L + \Delta k_{NL} = -D(I_1)c2p \left( \frac{\Delta I}{I_1} \right)^2 + \mathbf{g}(2P_1 - P_2) \quad (1)$$

As the equation shows, the phase mismatching depends on the local chromatic dispersion  $D$  (linear term) and on a nonlinear coefficient  $\mathbf{g}$  (nonlinear term). The Stokes signal can also be expressed as a spatial intensity oscillation with period  $I_{Sp}$ . Thus, the temporal oscillation frequency  $\mathbf{n}_t$  in intensity of the Rayleigh back-scattered light can be expressed as

$$\mathbf{n}_t = \frac{c}{2n} \frac{1}{I_{Sp}} = \frac{c}{2n} \frac{\Delta k}{2p} = \mathbf{n}_L + \mathbf{n}_{NL} = -\frac{c}{2n} Dc \left( \frac{\Delta I}{I_1} \right)^2 + \frac{c\mathbf{g}}{4np} (2P_1 - P_2) \quad (2)$$

If  $P_2 = 2P_1$  the nonlinear term is vanishing and a measurement of the local frequency allows to have information on the local value of the chromatic dispersion along the fiber distance. Once obtaining a map for the chromatic dispersion  $D(z, I)$  and considering a ratio for the pump and probe power different from two, we can in principle also retrieve an information on the local value of nonlinear coefficient  $\mathbf{g}(z)$  (*i.e.*  $n_2/Ae_{eff}$ ).

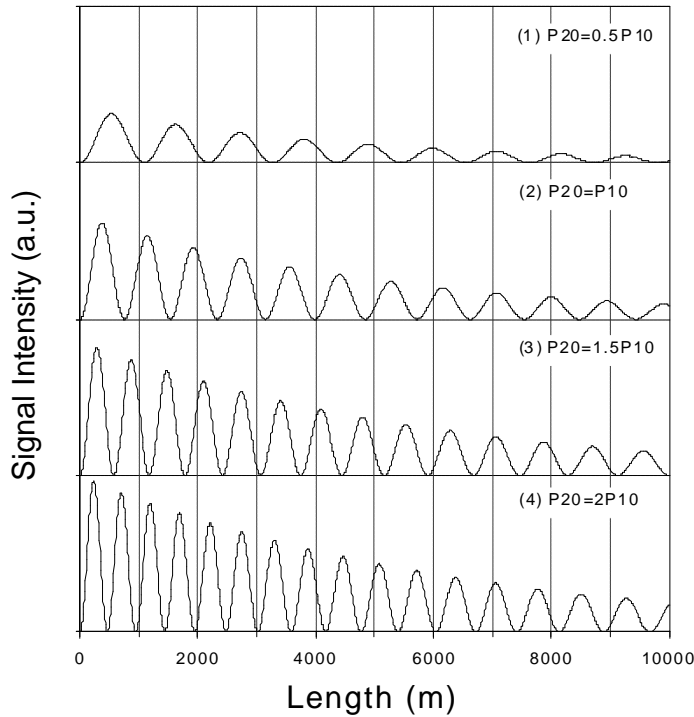

Fig.1 Four-wave mixing intensity oscillation versus fiber length for different ratio between probe and pump powers. Input pump power  $P_{10} = 1$  W and  $n_2 = 2.5 \times 10^{-20} \text{ m}^2/\text{W}$ .

The phase mismatch  $\Delta k$  leads to a temporal intensity oscillation of the Rayleigh back-scattered Stokes signal against the fiber length. Then it is able to give a map of the chromatic dispersion on a distance scale. However, in Eq.1 (or Eq.2) we do not take into account any polarization dependent effects. The relative polarization states of pump and probe vary according to polarization mode dispersion (PMD) of the fiber under test. For relatively large PMD values one can find that the change in the relative

polarization states would bring about two consequences. First, the FWM efficiency is polarization dependent. The detected signal intensity oscillations is related to both FWM intensity due to the phase mismatch of a local chromatic dispersion and an additional modulation due to the change in FWM efficiency by PMD. However, this PMD effect on FWM is usually not significantly big to wash away the FWM temporal intensity oscillation. As a second consequence of PMD, the FWM phase mismatch is polarization dependent. The phase seen by pump and probe beams can be different because of the local birefringence, therefore, to introduce an additional value to nonlinear term in Eq.2. As shown in Fig.1, any change of ratio between probe and pump power, the oscillation frequency of the Stokes signal would be changed. This can be important in fibers even with little polarization mode coupling. Thus, in such fiber polarization dependent phase shifts could strongly vary the oscillation frequency of the Stokes signal intensity to lead an uncertainty measurement of the distributed chromatic dispersion.

### 3. SETUP

The experimental setup for the distributed chromatic dispersion measurements is shown in Fig.2. The light sources consisted of two distributed feedback lasers (DFB) in cw mode with a maximum power of 20 mW (IQ-2400, EXFO Inc.). The laser frequency can be modulated by applying a small dither on current to avoid stimulated Brillouin scattering (SBS) effect in fiber under test. Two laser beams were combined by a 50:50 coupler, and then modulated by a semiconductor optical amplifier (SOA) with a frequency of 4 kHz and a pulse width of 30 ns. The extinct ratio of the pulse from SOA was of 50 dB. This pulse was amplified again by an EDFA (IQ-6100, EXFO Inc.) to several watts<sup>19, 20</sup>. Typically the pulse peak power in the range of 150 to 1500 mW was used for our measurements. The state-of-polarization (SOP) of the two lights was controlled by two polarization controllers, and made the same in order to optimize FWM intensity. The SOPs of both lights launched into the FUT were varied simultaneously by a third polarization controller. The total Rayleigh back-scattered signals from the FUT was collected through an optical circulator (C), and only the Stokes component of interest was isolated by a tunable band-pass filter with an 40 dB attenuation beyond  $\pm 1$  nm. The oscillation of the Stokes power was monitored as a function of fiber distance by controlling a semiconductor optical amplifier and the detector (APD) with a modified OTDR. Then from detected FWM signal the chromatic dispersion map can be extracted.

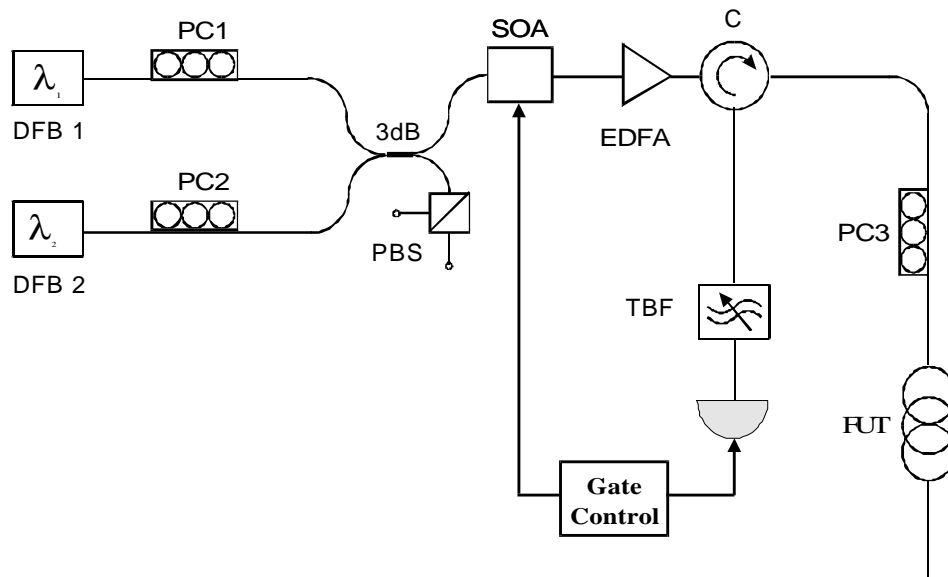

Fig.2 Experimental setup for the measurement of distributed chromatic dispersion. PC: polarization controller; TBF: tunable band-pass filter; and PBS: polarization beam splitter.

In the experiment we first demonstrated the measurement of a distributed chromatic dispersion map in a dispersion-shifted fiber with a low PMD of 0.02 ps/ $\sqrt{\text{km}}$ . Then we studied this measurement by using a

high PMD dispersion-shifted fiber (DSF) with PMD 0.19 ps/ $\sqrt{\text{km}}$ . The PMD was measured by a PMD analyzer (IQ-5500, EXFO Inc.).

## 4. RESULTS

### A. Chromatic dispersion map for a low PMD dispersion-shifted fiber

Fig.3 shows the Stokes signal intensity for a low PMD fiber for different input SOPs into the FUT where pump and probe input polarization were kept identical. No significant dependence of the results on the input polarization was expected for this fiber, as the pump and probe signals had no time to acquire significantly different phases due to the frequent coupling among the fast and slow axes. Indeed, the figure demonstrated that not only the small changes in the amplitudes, but also not in the locations of the Stokes signal maxima were obtained. For completeness, inset (b) shows the chromatic dispersion map was obtained from lights launched into the fiber from both ends (one of the profiles was inverted) and demonstrated good reproducibility and accuracy of the results. The spatial resolution of chromatic dispersion was typically of 250 m and an accuracy of  $\pm 0.02$  ps/(nm km) or better was observed. Inset (a) gives the overall dispersion at different wavelengths, where the open circles were obtained from summing up the FWM dispersion map and the bold line was from the method of phase-shift technique<sup>21-23</sup>. The results from these two methods were agreed very well.

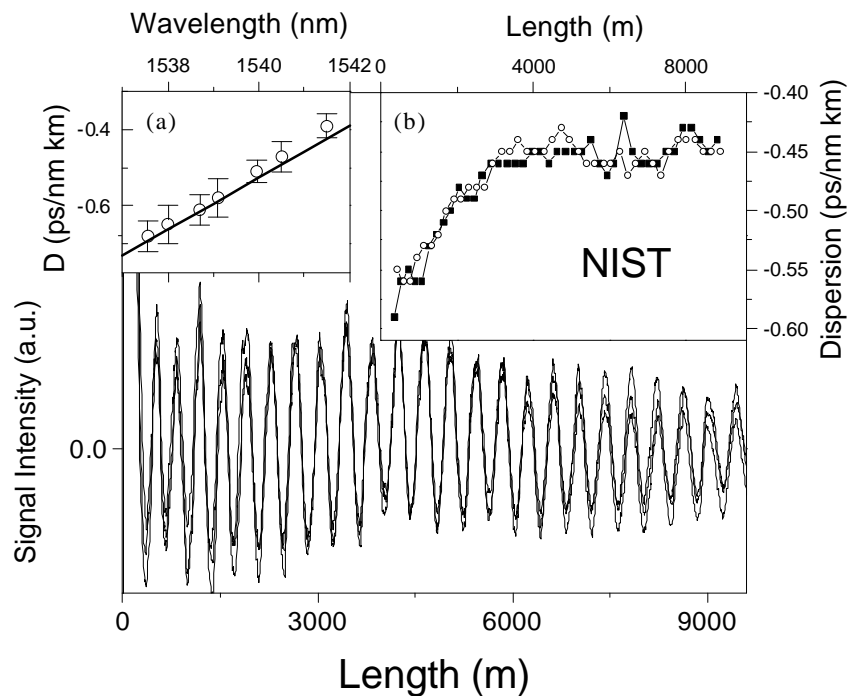

Fig.3 Typical traces of the Rayleigh back-scattered lights from a dispersion-shifted fiber with short coupling length. Insert (a) overall dispersion at different wavelength (circular) compared with phase-shifted method (solid line). Insert (b) a chromatic dispersion map.

Fig.4 shows a less  $\pm 4\%$  difference of chromatic dispersion magnitudes when the fiber was tested from different ends. We also observed that the chromatic dispersion map was varied very small as changing of wavelength separation between pump and probe beams.

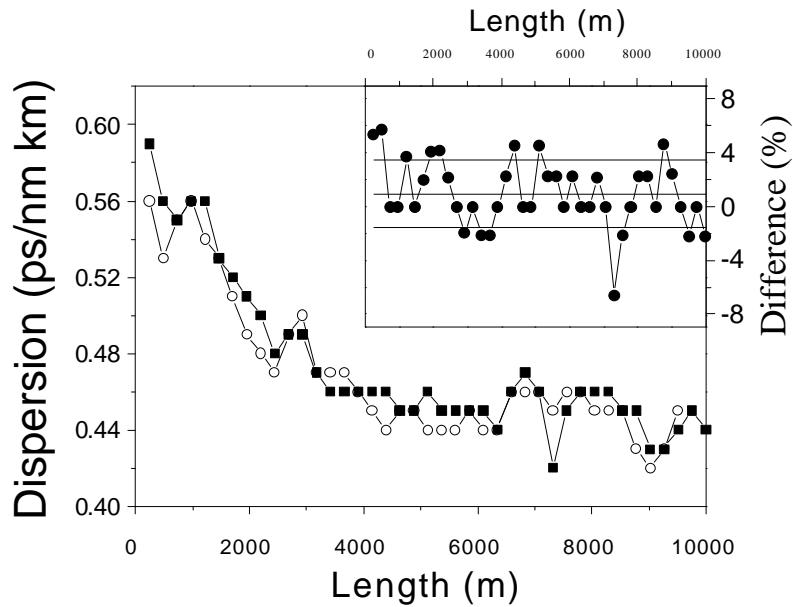

Fig.4 An example of chromatic dispersion map at wavelength 1541.3 nm from a dispersion-shifted fiber. Circles and squares are referred as the chromatic dispersion map obtained from the lights launched into the fiber from different ends. Insert figure shows a difference of chromatic dispersion values obtained from the lights entering into different fiber ends.

In Fig.5 we demonstrated distributed chromatic dispersion maps at different wavelengths. It shows clearly that dispersion maps are with a similar tendency except dispersion values with offsets for different wavelengths. Again we demonstrated a good reproducibility and accuracy of the tested results.

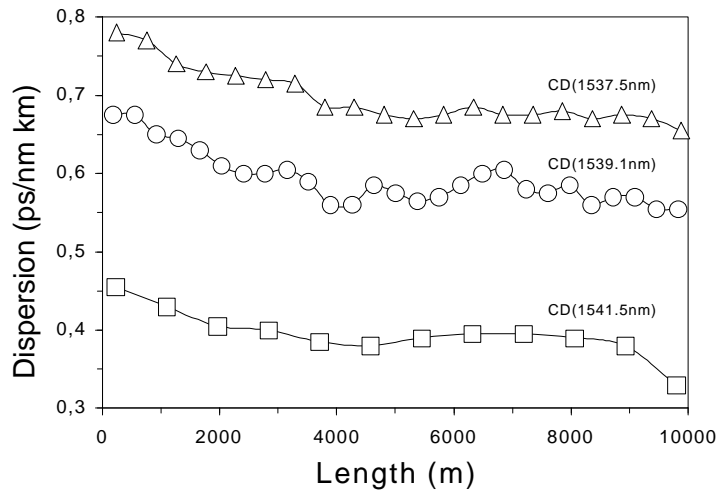

Fig.5 Chromatic dispersion maps for different wavelengths.

### B. Effect of PMD

We also measured chromatic dispersion for a high PMD dispersion-shifted fiber with PMD 0.19 ps/√km and found that it was difficult to extract the dispersion map. Fig.6 shows four-wave mixing intensity along distance for different SOPs. As can be seen, maximum locations of the Stokes signal were varied strongly

due to the additional phase from PMD, which depended on the input light polarization states. In fact, the chromatic dispersion map can no longer be estimated from a single trace alone, as the frequency at a given location depended on the (arbitrary) relative polarization states at that location for that input SOP. To remove this arbitrary component, different profiles, each corresponding to a different input SOP, had to be taken. For a given location, the mean value of group velocity delay (GVD) should then be retained. We point out that an averaging overall possible SOPs during an acquisition (by using a polarization scrambler) did not give a meaningful result, as it simply corresponds to a sum of the different individual traces giving - due to arbitrary positions of the different maxima - a curve that was basically flat. It was nearly impossible to extract a meaningful dispersion map from this measurement.

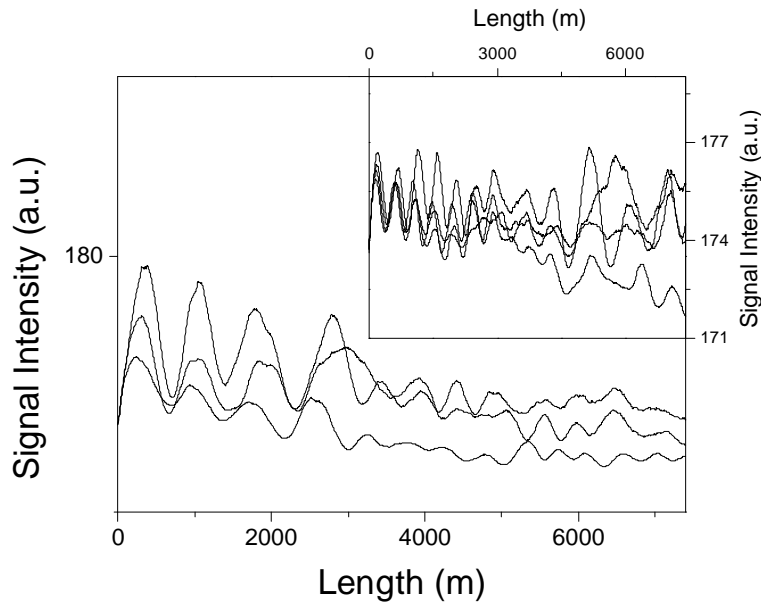

Fig.6 FWM intensity profile for a high PMD DSF fiber. Three traces correspond three input SOPs. The insert figure shows the input lights were launched from another fiber end.

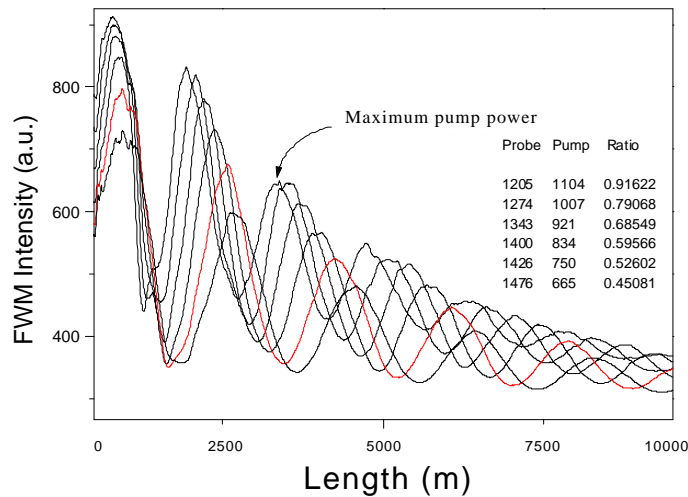

Fig.7 FWM intensity profiles for the different launched probe and pump powers.

### C. Effect of fiber nonlinearity and $n_2/A_{\text{eff}}$ measurement

As shown in simulation of Fig.1, the fiber nonlinear effect could introduce some additional phase mismatch if the  $P_2/P_1 \neq 2$ . Thus it is important to set  $P_2/P_1=2$  at any position of fiber in order to extract a precision local CD. Fig.7 shows experimental results of oscillation frequencies in the Stokes signal intensity was varied with ratio of pump and probe powers. This effect not only comes from fiber itself ( $n_2/A_{\text{eff}}$ ), but also could come from pump and probe power level and its ratio. This nonlinear phase mismatch makes complicated to extract a precision chromatic dispersion map.

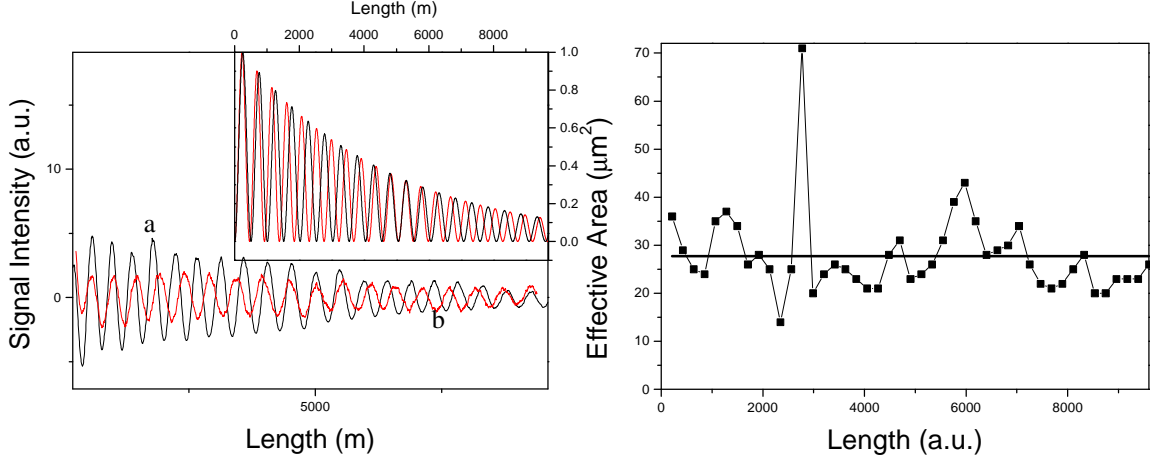

Fig.8 Left: measured FWM intensity for  $P_{10} = P_{20} = 1150$  mW (trace a) and  $P_{10} = P_{20} = 115$  mW (trace b) at wavelength 1541.3 nm and the insert figure is theoretical simulation using experimental parameters. Right: map of the  $A_{\text{eff}}$  for the short coupling length fiber for  $n_2 = 2.6 \times 10^{-20} \text{ m}^2/\text{W}$ .

However, the method of measurements of distributed chromatic dispersion can also be used to measure distributed nonlinear coefficient  $g$  (*i.e.*  $n_2/A_{\text{eff}}$ ) by fitting experimental data to the theoretical simulation. One simple method to measure distributed nonlinear coefficient is to take several measurements by using different input pump powers launched into FUT with a viable optical attenuator (VOA). Fig.8 (left) shows two four-wave mixing signal traces where launched pumped light power was attenuated by 10 dB. Clearly there are two fringes being missed from weaker pump power. The inserted figure shows our theoretical simulation using experimental parameters and it agrees with our experimental results very well. To extract a nonlinear coefficient map from above curves was possible<sup>24</sup> as shown in Fig.8 (right) for an  $A_{\text{eff}}$  map where we set  $n_2=2.5 \times 10^{-20} \text{ m}^2/\text{W}$  but not enough accuracy from these primarily results because of noise on tested curves.

## 5. DISCUSSION

In the previous sections, we described the spatial resolved chromatic dispersion map measurement in the low PMD or low polarization coupling length dispersion-shifted fibers. In order to increase the dynamic range, we amplified the pulse peak power to about 10 W and predicted that the measurable fiber distance could be of 40 km. In order to avoid the fiber nonlinear effect, one should choose the probe power twice as large as the pump power ( $P_2/P_1=2$ ) so the nonlinear phase mismatch is disappeared.

Even we demonstrated a promising measurement of chromatic dispersion maps with a precision and good spatial resolution. However, due to sensitivity of FWM efficiency and phase mismatch on light polarization by PMD, the meaningful distributed chromatic dispersion map may be impossible to obtain for some fibers where the polarization coupling length is too large. In fibers with low PMD, polarization does not affect the value of chromatic dispersion and a meaningful information about distributed chromatic

dispersion can be possible to be extracted from the resulting Stokes oscillation. For recently installed fibers with a low PMD, it would be possible to achieve a precision measurement by averaging over polarization to avoid ambiguous. We point out here that polarization dependent phase mismatch is strongly depend on probe and pump power level. Thus a relative weak power should be helpful to decrease the polarization effect, but it would limit measurable dynamic range.

The method of the distributed chromatic dispersion measurement using phase mismatched FWM may also be used to measure the distributed nonlinear coefficient of low PMD or low polarization coupling length fibers. Therefore, a meaningful nonlinear coefficient map may be obtained by fitting experimental data to simulation as indicated in second term of Eq.2. In our experiment we could clearly observe the Stokes oscillation moving when the pump and probe power were varied. A clear distributed nonlinear coefficient should be measurable if signal to noise ratio can be improved.

## 6. CONCLUSION

We demonstrated the distributed chromatic dispersion measurements in low PMD or low polarization coupling length dispersion-shifted fibers with a high spatial resolution and good accuracy based on the phase mismatched four-wave mixing. The impact of PMD and nonlinear effect on the measurements was also studied. In the experiment we observed that the mapping of chromatic dispersion in DSF fibers was strongly affected by their polarization coupling length. Nevertheless, the possibility to obtain a meaningful dispersion map in a fiber with low PMD still exists. However, it requires averaging of the dispersion values at a given location for different input SOPs to avoid ambiguous. The effect of nonlinear phase mismatch on Stokes signal for the measurement of chromatic dispersion map may lead to extract a distributed nonlinear coefficient  $n_2/A_{\text{eff}}$  as a function of fiber distance.

## ACKNOWLEDGMENTS

H. Chen would like to thank Drs G. He and N. Cry of EXFO Electro-Optical Engineering Inc., Quebec, Canada for providing helpful discussion. C. Vinegoni thanks to EXFO Electro-Optical Engineering Inc., Quebec, Canada for financial support during this research.

## REFERENCES

1. L.F. Mollenauer, P.V. Mamyshev and M.J. Nuebelt, 'Method for facile and accurate measurement of optical fiber dispersion maps', *Opt. Lett.*, vol.21, no.21, pp.1724, 1996.
2. N.G.R. Broderick, D.J. Richardson and L. Dong, 'Distributed dispersion measurements and control within continuously varying dispersion tapered fibers', *Opt. Lett.*, vol.9, no.11, pp.1511, 1997.
3. J. Gripp, L.F. Mollenauer, 'Enhanced range for OTDR-like dispersion map measurements', *Opt. Lett.*, vol.23, no.20, pp.1603, 1998.
4. M. Ohashi, M. Tateda, 'Novel technique for measuring longitudinal chromatic dispersion distribution in singlemode fibres', *Electron. Lett.*, vol.29, no.5, pp.426, 1993.
5. K.S. Abedin *et al*, 'Measurement of the chromatic dispersion of an optical fiber by use of a Sagnac interferometer employing asymmetric modulation', *Opt. Lett.*, vol.25, no.5, pp.299, 2000.
6. A. Rossaro, M. Schiano, T. Tambosso and D. D'Alessandro, 'Spatially resolved chromatic dispersion measurement by a bidirectional OTDR technique', *IEEE J. Select. Topic in Quantum Electron.*, vol.7, no.3, pp.475-483, 2001.
7. K. Nakajima, M. Ohashi, and M. Tateda, 'Chromatic dispersion distribution measurement along a single-mode optical fiber', *J. of Lightwave Technol.*, vol.15, no.7, pp.1095, 1997.
8. K.O. Hill, D.C. Johnson, B.S. Kawasaki and R.I. MacDonald, 'CW three-wave mixing in single-mode optics fibers', *J. App. Phys.*, 49(10), pp.5098, 1978.
9. R.H. Stolen and J.E. Bjorkholm, 'Parametric amplification and frequency conversion in optical fibers', *IEEE J. of Quantum Electron.*, vol.QE-18, no.7, pp.1062, 1982.
10. K. Inoue, 'Experimental study on channel crosstalk due to fiber four-wave mixing around the zero-dispersion wavelength', *IEEE J. of Lightwave Technol.*, vol.12, no.6, pp.1023, 1994.

11. K. Inoue, 'Four-wave mixing in an optical fiber in the zero-dispersion wavelength region', *J. of Lightwave Technol.*, vol.10, no.11, pp.1553, 1992.
12. L. Pringent, J.-P. Hamaide, 'Measurement of fiber nonlinear Kerr coefficient by four-wave mixing', *IEEE Photon. Technol. Lett.*, vol.5, no.9, pp.1092, 1993.
13. K. Inoue, 'Phase-mismatching characteristic of four-wave mixing in fiber lines with multistage optical amplifiers', *Opt. Lett.*, vol.17, no.11, pp.801, 1992.
14. I. Zacharopoulos, I. Tomkos, G. Guekos, 'Influence of phase mismatch on a spectral inverter based on four-wave mixing in dispersion-shifted fiber at 10 Gb/s', *IEEE Photon. Technol. Lett.*, vol.11, no.4, pp.430, 1999.
15. J. Hansryd, H. Sunnerud, P.A. Andrekson and M. Karlsson, 'Impact of PMD on four-wave-mixing-induced crosstalk in WDM system', *IEEE Photon. Technol. Lett.*, vol.12, pp.1261, 2000.
16. K. Inoue, 'Polarization effect on four-wave mixing efficiency in a single-mode fiber', *IEEE J of Quantum Electron.*, vol.28, no.4, pp.883, 1992.
17. S. Betti, M. Giaconi, 'Effect of the cross-phase modulation on WDM optical systems: analysis of fiber propagation', *IEEE Photon. Technol. Lett.*, vol.13, no.4, pp.305-307, 2001.
18. R.I. Killely, H.J. Thiele, P. Bayvel, 'Prediction of transmission penalties due to cross-phase modulation in WDM systems using a simplified technique', *IEEE Photon. Technol. Lett.*, vol.12, no.7, pp.804, 2000.
19. J. Nilsson, B. Jaskorzynska, 'Modeling and optimization of low-repetition-rate high-energy pulse amplification in cw-pumped erbium-doped fiber amplifiers', *Opt. Lett.*, vol.18, no.24, pp.2099, 1993.
20. B. Desthieux, R.I. Laming, R.I., D.N. Payne, '111 kW (0.5 mJ) pulse amplification at 1.5  $\mu$ m using a gated cascade of three erbium-doped fiber amplifiers', *Appl. Phys. Lett.*, vol.63, no.5, pp.586, 1993.
21. L.G. Cohen, 'Comparison of single-mode fiber dispersion measurement techniques', *J. of Lightwave Technol.*, vol. LT-3, no.5, pp.958-966, 1985.
22. Y. Horiuchi, 'Chromatic dispersion measurement in 1.55  $\mu$ m narrow-band region using a tunable external-cavity laser', *IEEE Photon. Technol. Lett.*, vol.1, no.12, pp.458, 1989.
23. K. Mori, T. Morioka, and M. Saruwatari, 'Ultrawide spectral range group-velocity dispersion measurement utilizing supercontinuum in an optical fiber pumped by a 1.5 $\mu$ m compact laser source', *IEEE Trans. on Instrumentation and Measurement*, vol.44, no.3, pp.712, 1995.
24. C. Vinegoni, H. Chen, M. Leblanc, G. Schinn, M. Wegmuller, and N. Gisin, 'Distributed measurements of chromatic dispersion and of nonlinear coefficient in DSF fibers with non negligible values of PMD', Paper WA5, OFC'2002, Anaheim, California, USA, 2002.